

EXISTING FRONTAGE 1:100

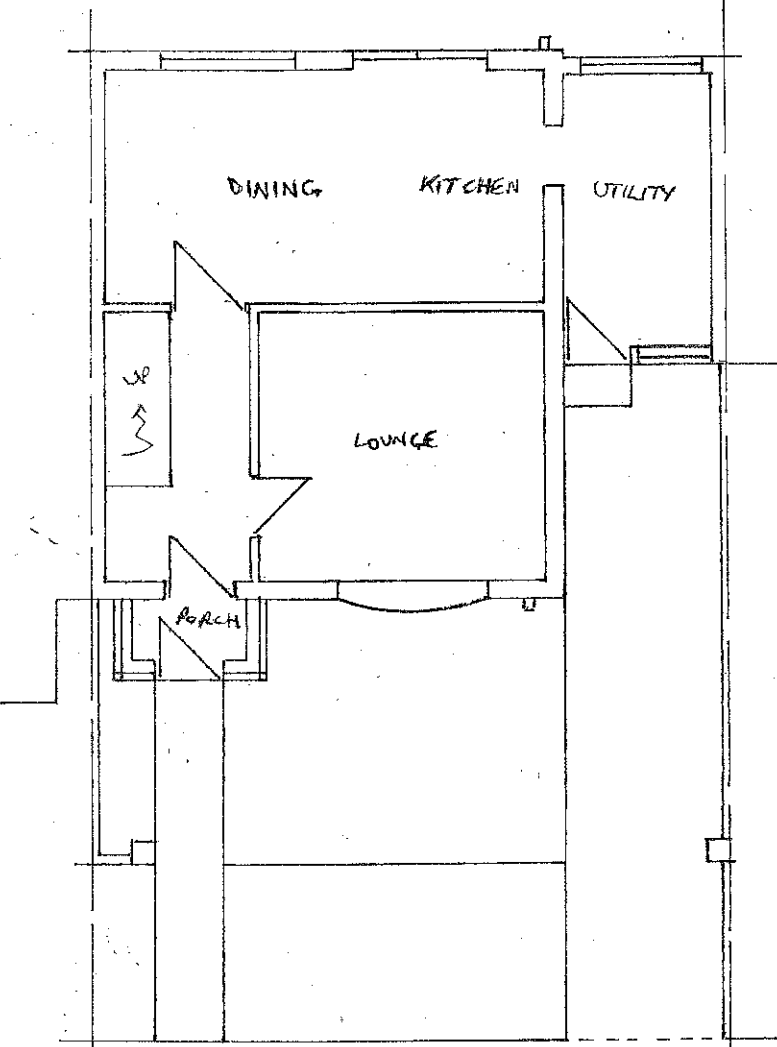

EXISTING SIDES 1:100

PROPOSED SIDE 1:100

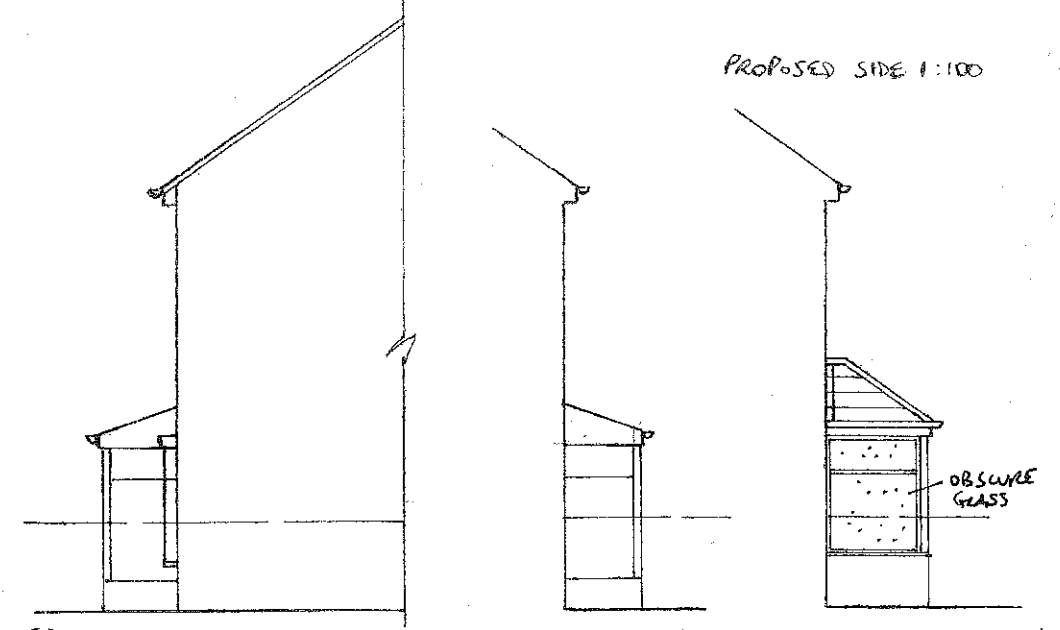

EXISTING PLAN 1:100



PROPOSED FRONTAGE 1:50

ROOF TILING, RED BRICK, WHITE UPVC FRAMING ETC. TO MATCH EXISTING AS CLOSELY AS POSSIBLE.

PROPOSED SIDE 1:100

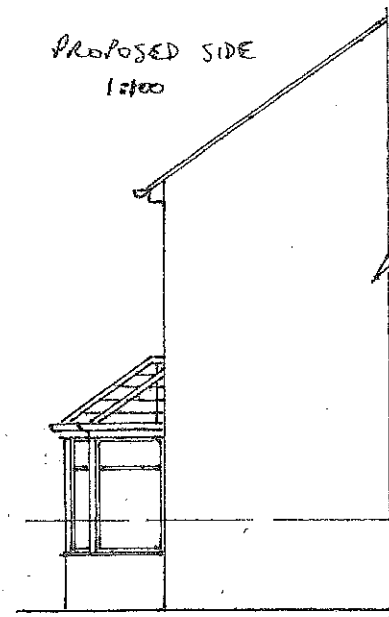

KITCHEN

LOUNGE

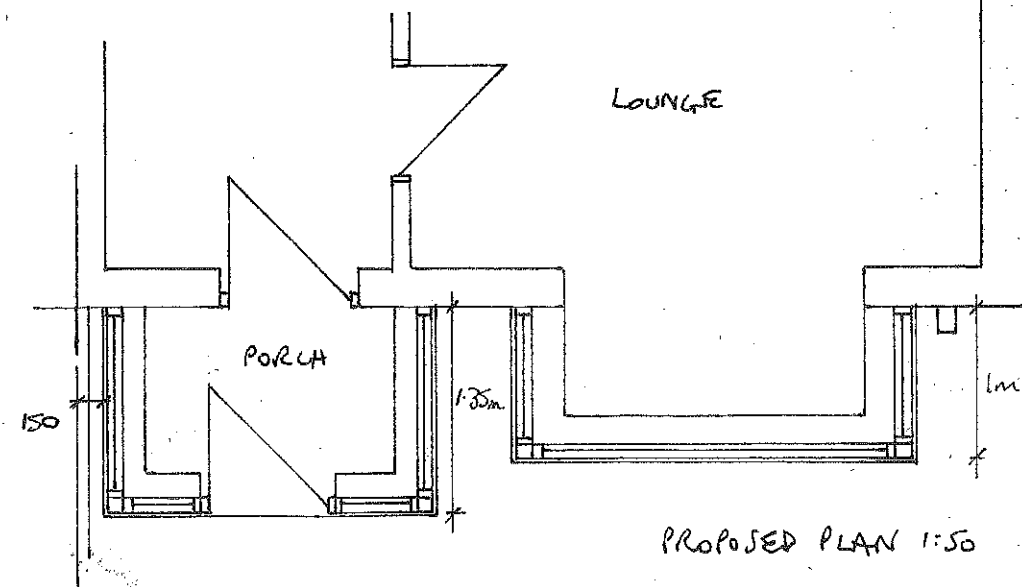

PROPOSED PLAN 1:50

PROPOSED EXTENSION TO 10 HYLTON AVE., S. SHIELDS FOR T. MARSHALL DRG NO 0771/0067/038